

LIBERATOR 4000



Ideal Crane LLC. is committed to designing and manufacturing the best electric hydraulic crane value in the industry. Our cranes are innovatively designed to perform to a higher standard of durability and reliability, and to provide the maximum duty cycle possible in an electric crane. For nearly 50 years we've backed that commitment with our limited lifetime structural warranty and factory direct technical support. You can be assured that your new Ideal Liberator crane will provide many years of dependable service.



4,000 lb. Max Capacity - 16,000 ft-lb Moment Rating

- ◆ Solid-state controls with Arc-Suppression circuits to extend life for switches and contactors.
- ◆ Large diameter swing bearing has stronger all-steel worm gear for positive "hillside" load locking.
- ◆ "eXtended On Time" hydraulic system increases duty cycle and prevents costly breakdowns.
- ◆ Meets OSHA 1910.180 and ANSI B30.5 specifications.

www.idealcrane.com

IDEAL CRANE L.L.C. - PO BOX 35249 - TULSA, OKLAHOMA 74153-0249

LIBERATOR 4000

- 4,000 lbs. Maximum Capacity
- 16,000 ft-lbs Crane Rating

SPECIFICATIONS

Liberator 4000 cranes come complete with 25 foot power cable, crane ground cable, a 225 amp fuse, a 4 foot frame grounding cable, 25' remote control pendant and owner's manual.

All Liberator 4000 cranes are shipped assembled, factory tested and ready to go to work.

Minimum chassis size, 10,500 GVW. 1000 amp CCA, deep cycle battery is required. A 150 amp alternator is recommended.

► Maximum Lifting Capacities ◀

4000 Lbs. @ 4 ft.	1777 Lbs. @ 9 ft.
3200 Lbs. @ 5 ft.	1600 Lbs. @ 10 ft.
2666 Lbs. @ 6 ft.	1333 Lbs. @ 12 ft.
2286 Lbs. @ 7 ft.	1143 Lbs. @ 14 ft.
2000 Lbs. @ 8 ft.	1000 Lbs. @ 16 ft.

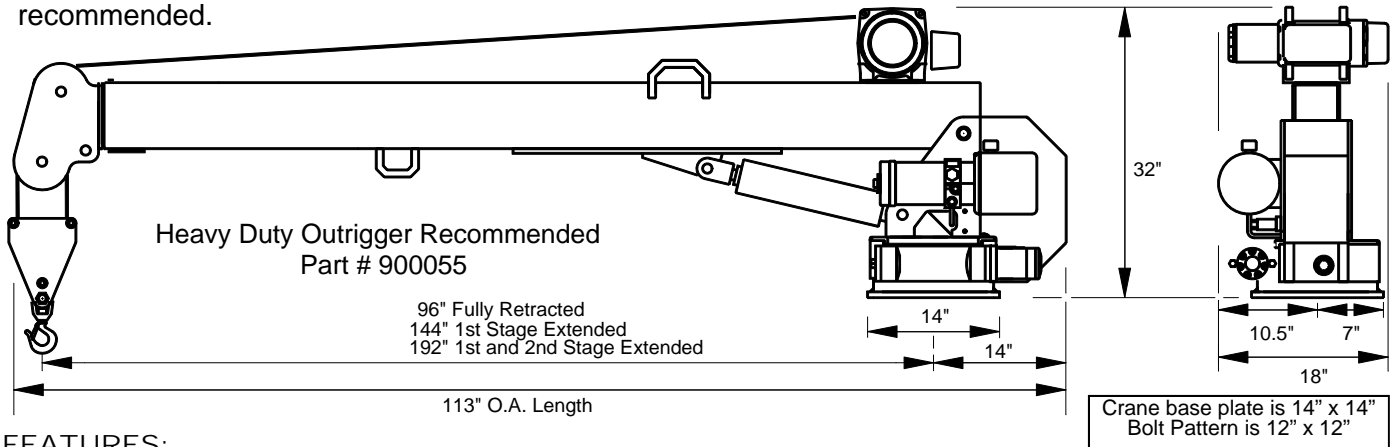

FEATURES:

- Self-contained 12 Volt DC hydraulic system supplies 2.2 gallons per min, powered by high-output extended on time series wound motor.
- Automatic overload protection prevents hoist up, boom extension and boom down.
- Anti two-block system standard on all cranes with power extension .
- Large diameter, self-locking, all steel worm gear rotation drive mounted on steel slewing ring crane bearing provides 360 degree continuous power rotation.
- Load cushioning counterbalance/check valves on all cylinders for precise load holding and handling.
- Safety valves on all cylinders prevents load drop if hose fails.
- 100% Solid-state control system with arc-suppression circuitry for extended life of switches, contactors and motors.
- 4,000 lb. max. capacity, 16,000 ft-lb moment rating.
- Hydraulic boom elevation from -5° to 75°.
- 25' remote control pendant with "Quik-Turn" connector.
- Planetary gear hoist is designed for maximum power, efficiency and hook speed.
- Industrial grade electrical contactors, no automotive type solenoids.
- 80' of 1/4" wire rope. Hoist drum and wire rope are on the outside of the boom where they are visible to the operator.
- Permanently lubricated polymer wire rope pulleys reduce wire rope wear.
- Boom extensions slide on low friction self-lubricating polymer slide pads.
- Meets OSHA 1910.180 requirements and ANSI B30.5. safety standards
- Powder coat finish for high gloss and durability.
- Mounting bolts provided (4 ea. 3/4" dia. gr 8).

Model	Power Boom	Power Extend	Manual Extend	Weight	O.A. Lgth Retracted	O.A. Width
LIB 4000 XTW-PR	Yes	No	8' to 12'	792#	9' 4"	18"
LIB 4000 XTW16-PR	Yes	No	8' to 16'	829#	9' 4"	18"
LIB 4000 PXTW-PR	Yes	8' to 12'	none	872#	9' 6"	18"
LIB 4000 PXTW16-PR	Yes	8' to 12'	12' to 16'	920#	9' 6"	18"



PO Box 35240 - Tulsa, Oklahoma 74153-0249
(800) 622-6163 fax (918) 234-0564
www.idealcrane.com

Distributed by: